

the sensor people

## rotoScan ROD4-30 / ROD4-36 / ROD4-38 Area Scanning Distance Sensor



en 03-2015/04 50127552  
We reserve the right to  
make technical changes

<b>1</b>	<b>General information .....</b>	<b>4</b>
1.1	Explanation of symbols .....	4
1.2	Declaration of conformity .....	4
<b>2</b>	<b>Safety .....</b>	<b>5</b>
2.1	Proper use .....	5
2.2	Foreseeable misuse.....	6
2.3	Competent persons.....	6
2.4	Disclaimer .....	6
2.5	Laser safety notices .....	7
2.6	Restrictions with regards to use .....	7
<b>3</b>	<b>Description .....</b>	<b>8</b>
3.1	Technical overview .....	8
3.2	Operating principle .....	9
3.3	Special features of the ROD4-3... ..	10
3.4	Detection fields / detection field pairs .....	10
3.4.1	Changing over between detection field pairs.....	11
3.4.2	4-field mode.....	13
3.5	Application examples .....	15
3.5.1	Object detection.....	15
3.5.2	Object measurement: .....	17
<b>4</b>	<b>Mounting.....</b>	<b>18</b>
<b>5</b>	<b>Electrical connection .....</b>	<b>19</b>
5.1	Connecting the rotoScan ROD4-3.....	19
5.1.1	Pin assignments X1 and X2.....	20
5.1.2	Connector assignments for connection X1 .....	21
5.1.3	Connector assignments for connection X2 (RS 232).....	23
5.1.4	Connector assignments for connection X2 (RS 422).....	23
5.2	Functions of connection X1 .....	24
5.2.1	Input circuit .....	24
5.2.2	Output circuit.....	26
5.2.3	RESTART / resetting the data transmission rate to 57600 baud.....	27
5.3	Functions of connection X2.....	28
5.4	Connection .....	28
5.4.1	Electrical supply.....	28
5.4.2	Fabricating the cable on the sensor side .....	28
5.4.3	Structure of the connector .....	29
5.4.4	Points to be observed when fabricating and laying the cable.....	30
5.5	Integration in the control system .....	31
5.5.1	Connection example 1: without detection field pair switch .....	31
5.5.2	Connection example 2: with detection field pair switch .....	32

<b>6</b>	<b>Commissioning</b> .....	<b>33</b>
6.1	Hardware and software requirements.....	33
6.2	Device configuration.....	33
6.3	Device configuration with ext. configuration memory / device exchange.....	35
6.4	Screwing down and aligning the device.....	36
6.5	Switching on the device.....	36
<b>7</b>	<b>Testing and maintenance</b> .....	<b>37</b>
7.1	Testing.....	37
7.2	Cleaning.....	37
<b>8</b>	<b>Delivery contents and accessories</b> .....	<b>38</b>
8.1	Scope of delivery.....	38
8.2	Accessories.....	38
8.2.1	Pin assignment for connection cables KB-ROD4-5000 and KB-ROD4-10000.....	39
8.2.2	BT ROD4 mounting system.....	40
<b>9</b>	<b>Technical data</b> .....	<b>41</b>
9.1	Detection field data.....	41
9.2	Electrical data.....	42
9.3	Software.....	42
9.4	Optical data.....	43
9.5	Environmental data.....	45
9.6	Dimensioned drawing ROD4-3.....	46
<b>10</b>	<b>Status messages, errors and error rectification</b> .....	<b>47</b>
10.1	LED indicators.....	47
10.2	Status displays.....	49
10.3	Diagnostic codes and causes.....	50
<b>11</b>	<b>Appendix</b> .....	<b>55</b>
11.1	Terms and abbreviations used with ROD4-3... and the RODsoft software.....	55

Tabelle 3.1:	Device types.....	8
Bild 3.1:	Measurement ranges and detection fields .....	8
Bild 3.2:	Working range and angular resolution .....	9
Bild 3.3:	Operating principle .....	9
Bild 3.4:	Configuring detection field pairs 1 through 4 only .....	11
Tabelle 3.2:	Changeover of the detection field pairs via the control inputs .....	12
Bild 3.5:	Also configuring detection field pairs 5 through 8.....	12
Tabelle 3.3:	Changeover of the detection field pairs via the control inputs .....	13
Tabelle 3.4:	Assignment of detection field to switching output in 4-field mode .....	13
Bild 3.6:	Application example - height/position detection .....	15
Bild 3.7:	Application example - Protusion detection in high-bay warehouses .....	15
Bild 3.8:	Application example - automatic parking system .....	16
Bild 3.9:	Application example - 4-field mode .....	16
Bild 3.10:	Application example - measurement of pallets.....	17
Bild 3.11:	Application example - gripping system .....	17
Bild 5.1:	Connecting the rotoScan ROD4-3.....	19
Tabelle 5.1:	Connections of the ROD4-3... – X1 and X2.....	20
Tabelle 5.2:	SUB-D 15-pin – pin assignments for connection X1 .....	21
Tabelle 5.3:	SUB-D 9-pin – pin assignments for connection X2 as RS 232 port .....	23
Tabelle 5.4:	SUB-D 9-pin – pin assignments for connection X2 as RS 422 port .....	23
Bild 5.2:	Inputs of interface X1 .....	24
Bild 5.3:	Example: Detection field pair switch for a DTS application .....	25
Bild 5.4:	Outputs of interface X1 .....	26
Bild 5.5:	Plug wiring.....	29
Bild 5.6:	Connection example without detection field pair switch .....	31
Bild 5.7:	Connection example with detection field pair switch .....	32
Bild 6.1:	User interface of the configuration software.....	34
Bild 6.2:	Switch in the config. connector.....	35
Bild 6.3:	LEDs.....	36
Bild 8.1:	Dimensioned drawing BT ROD4.....	40
Tabelle 9.1:	Technical data - detection fields .....	41
Tabelle 9.2:	Technical data - electrical data.....	42
Tabelle 9.3:	Technical data - software .....	42
Tabelle 9.4:	Technical data - optical data .....	43
Bild 9.1:	Object size/diffuse reflection as a function of distance for the ROD4-30/ROD4-36 ...	43
Bild 9.2:	Typical beam dimensions for the ROD4-3.....	44
Tabelle 9.5:	Technical data - environmental data .....	45
Bild 9.3:	Dimensioned drawing ROD4-3.....	46
Bild 10.1:	ROD4-3... LED indicators .....	47
Tabelle 10.1:	Status displays on the rotoScan ROD4-3.....	49
Tabelle 10.2:	ROD4-3... – diagnostic codes, causes and measures.....	50
Bild 11.1:	Components of the object speed.....	58

## 1 General information

### 1.1 Explanation of symbols

The symbols used in this technical description are explained below.



**Attention!**

*This symbol appears before text passages which must absolutely be observed. Failure to heed this information may lead to injuries to personnel or damage to the equipment.*



**Attention Laser!**

*This symbol warns of possible danger through hazardous laser radiation.*

*The laser used in the rotoScan ROD4-3... is an infrared laser device of laser class 1 acc. to DIN EN 60825-1. Observe the legal and local regulations applicable to the operation of laser units.*



**Notice!**

*This symbol indicates text passages containing important information.*

### 1.2 Declaration of conformity

The rotoScan ROD4-30, rotoScan ROD4-36 and rotoScan ROD4-38 distance sensors have been developed and produced in accordance with the applicable European standards and directives.

The rotoScan ROD4-3... distance sensors also fulfil the UL requirements (Underwriters Laboratory Inc.) for the USA and Canada.



**Notice!**

*The corresponding declaration of conformity can be requested from the manufacturer.*

The manufacturer of the product, Leuze electronic GmbH + Co. KG in D-73277 Owen/Teck, possesses a certified quality assurance system in accordance with ISO 9001.



## 2 Safety

This sensor was developed, manufactured and tested in line with the applicable safety standards. It corresponds to the state of the art.

### 2.1 Proper use

The ROD4-3... is an optical, two-dimensional measuring distance sensor.

#### **Areas of application**

The ROD4... series sensors are especially designed for the following areas of application:

- Height/position detection
- Overshoot detection (e.g. in fully automatic parking systems)
- Buffering protection (e.g. for telpher lines)
- Contour measurement
- Packet measurement / volume measurement



#### **CAUTION**

##### **Observe intended use!**

☞ Only operate the device in accordance with its intended use. The protection of personnel and the device cannot be guaranteed if the device is operated in a manner not complying with its intended use.

Leuze electronic GmbH + Co. KG is not liable for damages caused by improper use.

☞ Read the technical description before commissioning the device. Knowledge of this technical description is an element of proper use.

##### **NOTE**

##### **Comply with conditions and regulations!**

☞ Observe the locally applicable legal regulations and the rules of the employer's liability insurance association.

##### **OPERATION NOTICE IN ACCORDANCE WITH UL CERTIFICATION:**

**CAUTION – Use of controls or adjustments or performance of procedures other than those specified herein may result in hazardous light exposure.**

**ATTENTION ! Si d'autres dispositifs d'alignement que ceux préconisés ici sont utilisés ou s'il est procédé autrement qu'indiqué, cela peut entraîner une exposition à des rayonnements et un danger pour les personnes.**



#### **Attention**

*For UL applications, use is only permitted in class 2 circuits in accordance with the NEC (National Electric Code).*

## 2.2 Foreseeable misuse

Any use other than that defined under the "Approved purpose" or which goes beyond that use is considered improper use.

In particular, use of the device is not permitted in the following cases:

- Rooms with explosive atmospheres
- in circuits which are relevant to safety
- Operation for medical purposes

### NOTE

#### **Do not modify or otherwise interfere with the device.**

- ↳ Do not carry out modifications or otherwise interfere with the device. The device must not be tampered with and must not be changed in any way. The device must not be opened. There are no user-serviceable parts inside. Repairs must only be performed by Leuze electronic GmbH + Co. KG.

## 2.3 Competent persons

Connection, mounting, commissioning and adjustment of the device must only be carried out by competent persons.

Prerequisites for competent persons:

- They have a suitable technical education.
- They are familiar with the rules and regulations for occupational safety and safety at work.
- They are familiar with the technical description of the device.
- They have been instructed by the responsible person on the mounting and operation of the device.

### ***Certified electricians***

Electrical work must be carried out by a certified electrician.

Due to their technical training, knowledge and experience as well as their familiarity with relevant standards and regulations, certified electricians are able to perform work on electrical systems and independently detect possible hazards.

In Germany, certified electricians must fulfill the requirements of accident-prevention regulations BGV A3 (e.g. electrician foreman). In other countries, there are respective regulations that must be observed.

## 2.4 Disclaimer

Leuze electronic GmbH + Co. KG is not liable in the following cases:

- The device is not being used properly.
- Reasonably foreseeable misuse is not taken into account.
- Mounting and electrical connection are not properly performed.
- Changes (e.g., constructional) are made to the device.

## 2.5 Laser safety notices



### ATTENTION, INVISIBLE LASER RADIATION – LASER CLASS 1

The device fulfills the IEC 60825-1:2007 (EN 60825-1:2007) safety regulations for a product in **laser class 1** as well as the U.S. 21 CFR 1040.10 regulations with deviations corresponding to "Laser Notice No. 50" from June 24th, 2007.

- ↪ Adhere to the applicable legal and local regulations regarding protection from laser beams.
- ↪ The device must not be tampered with and must not be changed in any way.  
There are no user-serviceable parts inside the device.  
Repairs must only be performed by Leuze electronic GmbH + Co. KG.

## 2.6 Restrictions with regards to use

- Glass, highly reflective materials such as mirrors (luminosity coefficient > 10,000%) as well as objects which do not reflect any light back to the sensor could falsify the measurement value. Additional notices can be found in chapter 9.4.
- Do not expose the ROD4-3... to flying sparks (e.g. welding sparks); the front cover, among other parts of the system, will be damaged.
- Vapours, smoke, dust and all particles visible in the air could affect the measurement values and cause the semiconductor outputs to switch off.
- Avoid large temperature fluctuations.
- If a protective housing is provided for the sensor, the detection must not occur through additional window material (plastic, glass, etc.).
- Physical contact with the front cover of the sensor and the six diffused-light windows is to be avoided.

### 3 Description

#### 3.1 Technical overview

Designation	Type	Part No.
rotoScan ROD4-30	without heater	501 10238
rotoScan ROD4-36	with integrated heater	501 10666
rotoScan ROD4-38	with integrated heating, dust-insensitive version	501 10667

Tabelle 3.1: Device types

The ROD4-3... is an optical, two-dimensional measuring distance sensor. It could also be referred to as an optical, area radar unit. The device periodically transmits light pulses within an angular range of 190° via a rotating deflector unit.

If the pulses are incident upon objects or obstacles, the light is reflected and then received and analysed by the ROD4-3.... From the propagation time of the radiated light and the current angle of the deflector unit, the ROD4-3... unit calculates the exact coordinates of the object. If the object or obstacle is located within defined detection fields, a stop function is executed. In this case, the semiconductor switch outputs are switched off within the system reaction time. The stop function is automatically reset once the detection field is clear or upon acknowledgement, depending on the operating mode (software configuration: manual/automatic).

The ROD4-3... can detect objects with diameters greater than 20mm at a distance of up to 4.0m, even if the surface of the given object is dark. Larger objects are detected in the **far** detection field at a distance of up to 50m.

Eight reversible detection field pairs (7 configurable + 1 permanently defined) enable optimal adaptation to the applications.



Bild 3.1: Measurement ranges and detection fields

The ROD4-3... can be used both on vehicles (mobile object detection for vehicles) as well as in stationary applications on systems and machines (object detection/measurement). The long-range and contact-less measurement principle makes the ROD4-3... unit a universally applicable monitoring device.

### 3.2 Operating principle

The working range of the ROD4-3... (190°) is divided into 0.36° angular segments (corresponds to 529 measurement values).

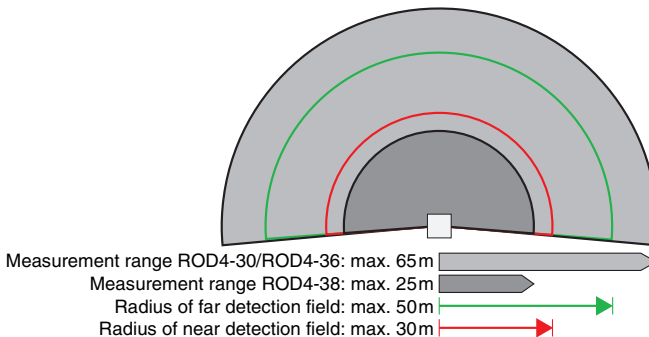

Bild 3.2: Working range and angular resolution

Bundled light pulses are generated by a laser diode with coupled transmission optics. These light pulses are reflected by a rotating mirror in such a way that a light pulse is emitted every 40ms in all angular segments (scanning rate: 25 scans/s). If the light pulse is incident upon an object, it is reflected and subsequently detected and analysed by the ROD4-3....

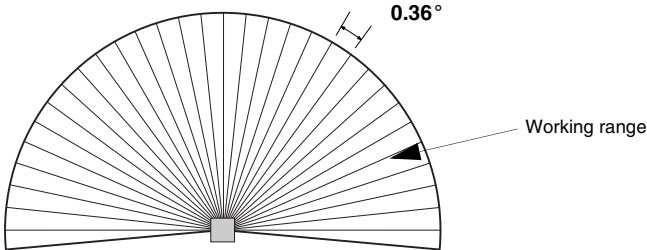

Bild 3.3: Operating principle

The ROD4-3... works on the principle of pulse propagation time measurement. The light pulse propagation time is a direct measurement of the distance to the object.

#### Reference measurement

A reference measurement cyclically controls the measurement function. The following functions are checked on each rotation of the mirror by means of a test object located inside of the device:

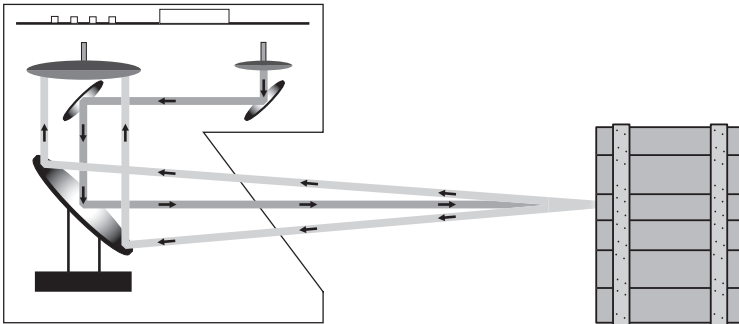
- optical systems (e.g. transmitter and receiver)
- hardware, software, etc.

### ***Window monitoring***

A total of six light axes monitor the degree of soiling of the window. During this procedure, the results are compared with two reference sensors. Moreover, these reference sensors are used for temperature compensation and ageing monitoring.

### ***Combination of hardware and software***

You can configure the ROD4-3... yourself using the supplied **RODsoft** software. In addition to the device configuration, the software can also be used to adapt the field pairs to the given application and to save them in the ROD4-3...

The image of the surroundings generated during the scan process is compared with the specified detection field contours. If an object violates a detection field for a least one scan (40ms), a corresponding, user-specific reaction is triggered.

## **3.3 Special features of the ROD4-3...**

- Seven freely configurable **near** detection fields (up to maximum 30m)
- Seven freely configurable **far** detection fields (up to maximum 50m)
- Monitoring range up to 190°
- Small construction size (W x D x H: 140mm x 135mm x 155mm)
- Low weight (2kg)
- Low current consumption (ROD4-30 without heating)
- Two interface types on the X2 SUB-D socket (RS 232 and RS 422)
- Easy-to-use **RODsoft** configuration software
- Measurement value transmission from distances of up to 65m
- Device plug with configuration memory facilitates simple exchange of devices

## **3.4 Detection fields / detection field pairs**

Eight reversible detection field pairs (7 configurable + 1 permanently defined) enable optimal adaptation to the applications. A detection field pair is considered to be the combination of both a **near** and **far** detection field. The following designations are used in the **RODsoft** configuration software:

**Detection field pair x** consists of **detection\_field\_near x** and **detection\_field\_far x**.

The **near** and **far** detection fields are represented by different colours in the RODsoft configuration software: **near** = red, **far** = green.

Detection field pairs 1 ... 7 can be freely defined by the user. Detection field pair 8 is permanently defined: both **detection\_field\_near 8** as well as **detection\_field\_far 8** are set to zero here. This means that no area monitoring takes place upon activation of detection field pair 8.

### 3.4.1 Changing over between detection field pairs



**Attention!**

*1 or 2 detection field pairs may be simultaneously active and simultaneously monitored!*

**Only detection field pairs 1 through 4 are configured**

If only detection field pairs 1 through 4 are configured in the **RODsoft** configuration software, i.e. it is only possible to start with a field pair between 1 and 4 and it is only possible to changeover between a field pair between 1 and 4, then a maximum of 2 detection field pairs may be simultaneously active and monitored.

Admissible pairs of fields (ZP) for scanner startup

1	2	3	4	5	6	7
x	x	x	x			

You may start with ZP1, ZP2, ZP3, ZP4

---

Admissible field pair changeovers

		to								
			1	2	3	4	5	6	7	8
from	1	-	x	x	x					
	2	x	-	x	x					
	3	x	x	-	x					
	4	x	x	x	-					
	5					-				
	6						-			
	7							-		

You may switch from ZP1 to ZP2, ZP3, ZP4

You may switch from ZP2 to ZP1, ZP3, ZP4

You may switch from ZP3 to ZP1, ZP2, ZP4

You may switch from ZP4 to ZP1, ZP2, ZP3

No changeover to other field pairs is permissible.

No changeover to other field pairs is permissible.

No changeover to other field pairs is permissible.

Bild 3.4: Configuring detection field pairs 1 through 4 only

The four control inputs FPS1 ... FPS4 can be used to change over between the detection field pairs. The following table shows the admissible control options.

Control input				Meaning
FPS1	FPS2	FPS3	FPS4	
0	0	0	0	Detection field pair 1 is active
1	0	0	0	Detection field pair 1 is active
0	1	0	0	Detection field pair 2 is active
1	1	0	0	Detection field pairs 1 and 2 are active
0	0	1	0	Detection field pair 3 is active
1	0	1	0	Detection field pairs 1 and 3 are active
0	1	1	0	Detection field pairs 2 and 3 are active
1	1	1	0	<b>Not permitted</b>
0	0	0	1	Detection field pair 4 is active
1	0	0	1	Detection field pairs 1 and 4 are active

Control input				Meaning
FPS1	FPS2	FPS3	FPS4	
0	1	0	1	Detection field pairs <b>2 and 4</b> are active
1	1	0	1	<b>Not permitted</b>
0	0	1	1	Detection field pairs <b>3 and 4</b> are active
1	0	1	1	<b>Not permitted</b>
0	1	1	1	<b>Not permitted</b>
1	1	1	1	<b>Not permitted</b>

Tabelle 3.2: Changeover of the detection field pairs via the control inputs

If an inadmissible state exists at the control inputs for more than 80ms, the sensor switches to the error state.

### **One of detection field pairs 5 through 8 is also configured**

If, in addition detection field pairs 1 through 4, at least one of detection field pairs 5 through 8 is also configured in the **RODsoft** configuration software, i.e. it is possible to start with a field pair between 1 and 7 and it is possible to changeover between a field pair between 1 and 8, then only 1 detection field pair may be simultaneously active and monitored.

Admissible pairs of fields (ZP) for scanner startup

1	2	3	4	5	6	7
x	x	x	x	x	x	x

You may start with ZP1, ZP2, ZP3, ZP4, ZP5, ZP6, ZP7

Admissible field pair changeovers

		to							
		1	2	3	4	5	6	7	8
from	1	-			x				x
	2		-			x	x	x	
	3	x		-					
	4	x		x	-				x
	5		x			-			
	6		x			x	-		
	7			x		x		-	

You may switch from ZP1 to ZP4, ZP8  
 You may switch from ZP2 to ZP5, ZP6, ZP7  
 You may switch from ZP3 to ZP2  
 You may switch from ZP4 to ZP1, ZP3, ZP8  
 You may switch from ZP5 to ZP2  
 You may switch from ZP6 to ZP2, ZP5  
 You may switch from ZP7 to ZP3, ZP4

Bild 3.5: Also configuring detection field pairs 5 through 8

In this case, the four control inputs can be used to change over between the detection field pairs as follows.

Control input				Meaning
FPS1	FPS2	FPS3	FPS4	
0	0	0	0	Detection field pair <b>1</b> is active
1	0	0	0	Detection field pair <b>1</b> is active
0	1	0	0	Detection field pair <b>2</b> is active
0	0	1	0	Detection field pair <b>3</b> is active
0	0	0	1	Detection field pair <b>4</b> is active

Control input				Meaning
FPS1	FPS2	FPS3	FPS4	
1	1	1	0	Detection field pair 5 is active
1	1	0	1	Detection field pair 6 is active
1	0	1	1	Detection field pair 7 is active
0	1	1	1	Detection field pair 8 is active
1	1	0	0	<b>Not permitted</b>
1	0	1	0	<b>Not permitted</b>
0	1	1	0	<b>Not permitted</b>
1	0	0	1	<b>Not permitted</b>
0	1	0	1	<b>Not permitted</b>
0	0	1	1	<b>Not permitted</b>
1	1	1	1	<b>Not permitted</b>

Tabelle 3.3: Changeover of the detection field pairs via the control inputs

While changing over between 2 detection field pairs, inadmissible states at the control inputs are tolerated for a duration of 40ms; after this period the sensor switches to the error state. The changeover between 2 detection field pairs occurs within a system reaction time of 80ms.

### 3.4.2 4-field mode

In 4-field mode (configuration via RODsoft), all 4 detection fields of detection field pairs 1 and 2 are simultaneously activated and evaluated. In this case, a separate output is assigned to each detection field pair.

Detection field	Switching output			
	Fn1	Fn2	ALARM1	ALARM2
Detection_field_near 1	X			
Detection_field_near 2		X		
Detection_field_far 1			(X)	
Detection_field_far 2				X

Tabelle 3.4: Assignment of detection field to switching output in 4-field mode

Inputs FPS1 ... FPS4 are not evaluated in 4-field mode. Detection field changeover is not possible in 4-field mode.



**Attention!**

Depending on the configuration, output ALARM1, in some cases, also signals device warnings. This means that a violation of detection\_field\_far 1 is not uniquely signalled under certain circumstances.

All outputs are switched off during start-up. Outputs ALARM1 and ALARM2 are activated during configuration.



**Notice!**

### **Operation with 3 detection fields**

*If only three detection fields are to act on three outputs, only use `detection_field_near 1`, `detection_field_near 2` and `detection_field_far 2` and set the alarm signal type for `ALARM1` to "Device warning". The output will then only signal device warnings and is, as a result, unique.*

### **Operation with 2 detection fields**

*If only two or fewer independent outputs are needed, 4-field mode is not required and should be deactivated with the appropriate `RODsoft` parameter.*

### 3.5 Application examples

The following examples can be considered typical areas of application for the ROD4-3...

#### 3.5.1 Object detection

##### ***Height/position detection***

Height and position detection of objects for collision prevention.



Bild 3.6: Application example - height/position detection

##### ***Protusion detection in high-bay warehouses***

Overshoot detection for collision prevention with high-bay storage devices.

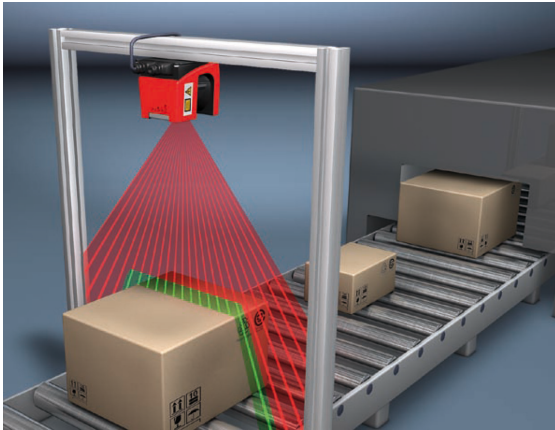

Bild 3.7: Application example - Protusion detection in high-bay warehouses

***Automatic parking system***

Protrusion detection in parking systems under changing environmental conditions.

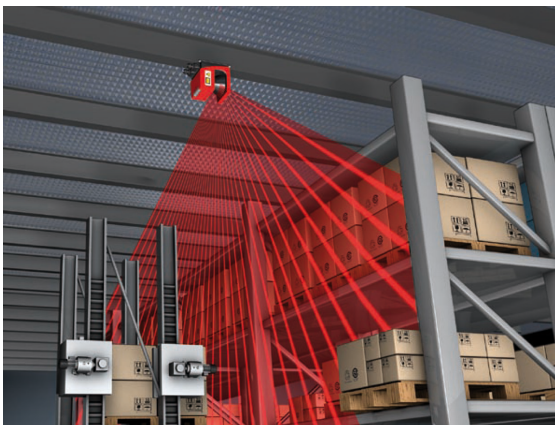

Bild 3.8: Application example - automatic parking system

***4-field mode***

Presence detection on the transport system with 4 independent detection fields.



Bild 3.9: Application example - 4-field mode

### 3.5.2 Object measurement:

#### ***Measurement of pallets***

Contour measurement, determination of X, Y coordinates.

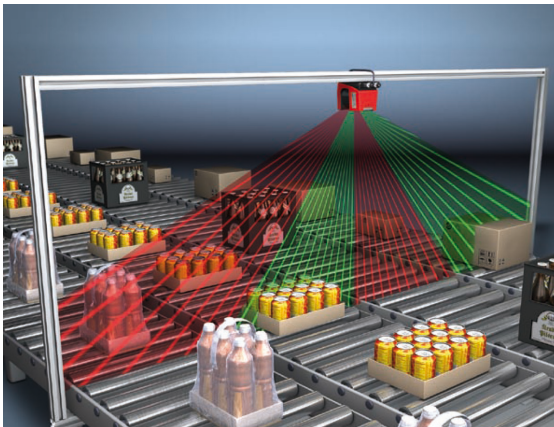

Bild 3.10: Application example - measurement of pallets

#### ***Manipulator positioning***

Compact construction and low weight enable use on gripping head.

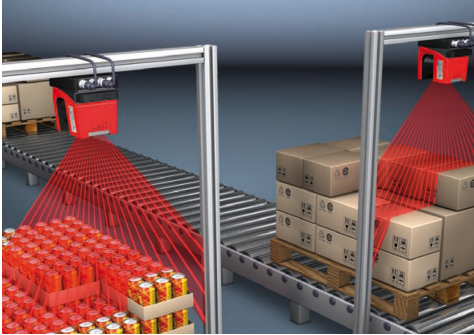

Bild 3.11: Application example - gripping system

#### ***Other applications***

- Buffering protection (e.g. for telfer lines)
- Overshoot detection (e.g. in fully automatic parking systems)
- Detection / counting of persons
- Room security / façade monitoring
- Access control
- Contour measurement
- Packet measurement / volume measurement
- etc.

## 4 Mounting

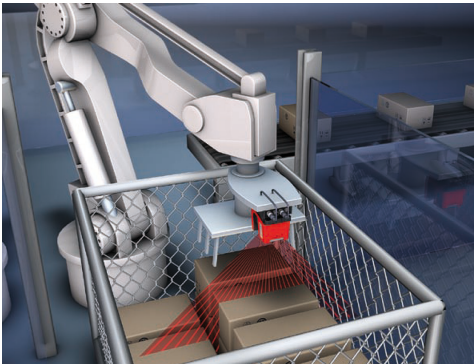
The ROD4-3... should be mounted so that the area which is to be monitored is covered by the corresponding detection field.



### **Attention!**

*Because of the optical scanning principle, only objects with good reflective properties are detected directly in front of the sensor window.*

*Physical damage to the sensor (e.g. due to collision or climbing on) should be prevented by using a protective enclosure. If using an enclosure, the entire front cover of the device must, however, remain unobstructed.*

In order for the ROD4-3... to function optimally, it must be mounted in a favourable position. You should make every effort to observe the following points:

- Position the ROD4-3... in a protected location.
- The mounting location and the electrical supply should be located as close as possible to one another.
- The ROD4-3... is to be mounted so that the area which is to be monitored is completely covered by the detection field.
- The mounting position of the sensor must offer protection from humidity, soiling, as well as temperatures below 0°C (ROD4-30) or -20°C (ROD4-36, ROD4-38) and above 50°C.
- The mounting location is to be selected such that the possibilities for mechanical damage are minimised. Exposed locations are to be equipped with additional protective guards or loop guards.
- Reinforcements, enclosures, mounting alcoves and other machine elements must not result in an obstruction in the sensor's field of vision.
- Retro-reflectors or very reflective surfaces, such as certain metals or ceramics, are to be avoided near the detection fields and at the height of the scanning plane as these may result in measurement errors.
- To ensure a constant detection height at every point in the detection field, the sensor, and thus the beam plane, is to be mounted parallel to the reference plane.
- If the sensor is used without start disable or start test with automatic start/restart, a start warning (optical/acoustic) is to be provided.
- The sensor must not be used as a climbing aid. If there is a risk of this, a suitable, inclined (45°) protector is to be mounted.
- If two sensors are used, they should be angled slightly with respect to one another or be mounted at different heights.

The device dimensions and the reference of the scanning plane to the device edges can be found in the dimensioned drawing (see figure 9.3 on page 46). Here, the zero point for the distance measurement is the axis of rotation of the rotating mirror (**a** in figure 9.3). BT ROD4... mounting system see chapter 8.2.2.



### **Notice!**

*Under certain circumstances, a larger measurement inaccuracy may occur with strongly reflective backgrounds (e.g. retro-reflectors, polished metal, etc.).*

## 5 Electrical connection

### 5.1 Connecting the rotoScan ROD4-3...

To configure the sensor, connect the control cable (KB-ROD4-..., socket X1) to the power supply and the interface cable (KB-ROD4PC-..., socket X2) to the PC or laptop. Before commissioning the system, please check the pin assignments, the wiring, the supply voltage and the safeguarding. In spite of the sensor's robust housing and fittings, which include various internal safety mechanisms, **damages resulting from misconnection** cannot be excluded.



Bild 5.1: Connecting the rotoScan ROD4-3...



#### **Attention!**

In normal operation, you **must** permanently connect the two Sub-D connectors to the ROD4-3... If one of the two connectors is missing, the ROD4-3... no longer has protection class IP 65.

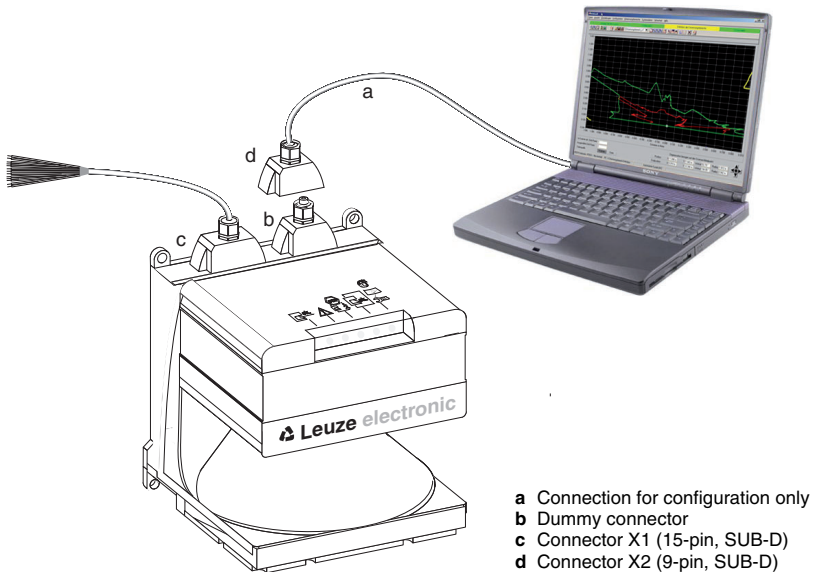
### 5.1.1 Pin assignments X1 and X2

Connection	Connector	Signals
<b>X1</b>	SUB-D 15-pin	<ul style="list-style-type: none"> <li>• Power supply</li> <li>• Switching outputs/alarm output</li> <li>• Inputs for field pair switch</li> <li>• Restart/reset input</li> <li>• Configuration connector</li> </ul>
<b>X2</b>	SUB-D 9-pin	rotoScan ROD4-3... <-> PC interface <ul style="list-style-type: none"> <li>• Parameter configuration</li> <li>• Detection field definition</li> <li>• Measurement data transmission</li> <li>• Diagnostics</li> </ul>

Tabelle 5.1: Connections of the ROD4-3... – X1 and X2

5.1.2 Connector assignments for connection X1

	PIN	Signal	Description	Wire colour KB-ROD4-...
	1	GND	Supply voltage ground	black
	2	Restart	Safe input "restart-disable", reset the sensor and connection of the restart button	blue
	3	UB	Supply voltage +24VDC	red
	4	FPS1	Changeover of detection field pairs	orange
	5	ALARM1	Output for object detection in the <b>far</b> detection field and for warning messages such as "Window lightly soiled" or "Window heavily soiled" (configurable). 4-field mode: Output for object detection in detection_field_far 1	yellow
	6	FPS2	Changeover of detection field pairs	green
	7	FPS3	Changeover of detection field pairs	violet
	8	FPS4	Changeover of detection field pairs	grey
	9	NC	Do not use!	–
	10	NC	Do not use!	–
	11	Fn1	Semiconductor output, shutdown on object detection in the <b>near</b> detection field, channel 1. 4-field mode: Output for object detection in detection_field_near 1	white
	12	Fn2	Semiconductor output, shutdown on object detection in the <b>near</b> detection field, channel 2. 4-field mode: Output for object detection in detection_field_near 2	white/black
	13	NC	Do not use!	–
	14	NC	Do not use!	white/brown
	15	ALARM2	Warning and error output 4-field mode: Output for object detection in detection_field_far 2	brown

Tabelle 5.2: SUB-D 15-pin – pin assignments for connection X1

**Attention!**

Any additionally used switching components (e.g. button for restarting) must be permanently mounted.

- Loosely position the button at the intended position.
- Switch on the voltage supply of the ROD4-3... which has been configured for the application.
- Violate the active **near** detection field, e.g. by entering it. The violation is indicated by the following status display (see also chapter 10.1):

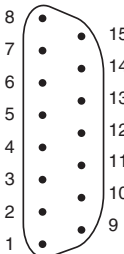

Red LED illuminated:  
outputs Fn1 and Fn2 disabled

Yellow LED with continuous light:  
restart-disable active

- Now actuate the restart button and observe the left, green LED. If this LED illuminates, you are no longer in the **near** detection field and the location of the button is suitable. If the LED does not illuminate, there are still objects located within the **near** detection field. In this case, change the location of the button and perform the test again.

### 5.1.3 Connector assignments for connection X2 (RS 232)

	PIN	Signal	Description
	1	NC	Do not use!
	2	TxD	Data communication, transmission
	3	RxD	Data communication, reception
	4	NC	Do not use!
	5	GND/shield	Ground/shielding (to be connected only on the cabinet side with PE)
	6	RS 232	Selection RS 232/RS 422, selection as RS 232 interface: do not use!
	7	NC	Do not use!
	8	NC	Do not use!
	9	Reserved	Reserved for test purposes, not wired

Tabelle 5.3: SUB-D 9-pin – pin assignments for connection X2 as RS 232 port

### 5.1.4 Connector assignments for connection X2 (RS 422)

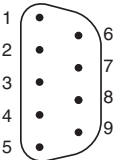

**Notice!**

*If you would like to work with an RS 422 interface, you must connect PIN 6 with PIN 5 (GND) by means of a bridge.*

	PIN	Signal	Description
	1	TxD+	RS 422 transmitted data
	2	TxD-	
	3	RxD-	RS 422 received data
	4	RxD+	
	5	GND/shield	Ground/shielding (to be connected only on the cabinet side with PE)
	6	RS 422	Selection RS 232/RS 422, selection as RS 422 interface: bridge to PIN 5!
	7	NC	Do not use!
	8	NC	Do not use!
	9	Reserved	Reserved for test purposes, not wired

Tabelle 5.4: SUB-D 9-pin – pin assignments for connection X2 as RS 422 port

## 5.2 Functions of connection X1

### 5.2.1 Input circuit

There are two Sub-D connections on the top of the device. At connection X1 with the 15-pin Sub-D connector, a ready-made cable (KB-ROD4-...) or a cable self-made by the customer is attached to the solder connections of the connector (connector set KD-ROD4-X1) by means of soldered connections (see figure 5.5).

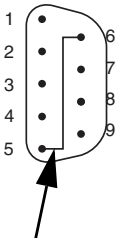

Bild 5.2: Inputs of interface X1

#### Inputs FPS1 ... FPS4

With the ROD4-3..., it is possible to work with up to eight detection field pairs. Use inputs **X1-4** (FPS1), **X1-6** (FPS2), **X1-7** (FPS3) and **X1-8** (FPS4) to switch between the detection field pairs.

Detection field pairs are activated by applying +24VDC (logic: 1) to the appropriate inputs. If no input is wired, detection field pair 1 is activated.

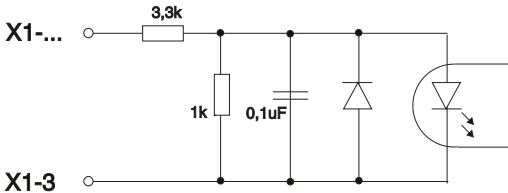

#### Notice!

The configuration-dependent changeover of detection field pairs is described in chapter 3.4.1 on page 11.



#### Attention!

If an **inadmissible signal combination** (e.g. 1-1-1-1) is applied at inputs FPS1 ...FPS4, a **warning is output at output ALARM2** and **outputs Fn1/Fn2 are switched off**. In addition, an error is transmitted via the serial interface and stored in the error memory.

The following situation would be possible with a DTS application (see figure 5.3):

The vehicle enters an intersection area while detection field pair 1 (I) is activated (Ⓢ). To prevent objects from colliding, detection field pair 2 (II) is switched on as well before the curve (↘). Both detection fields (I + II) are now active. Detection field pair 1 (I) is switched off. The vehicle travels around the curve with detection field pair 2 (II) active (↘). Afterward, detection field pair 1 (I) is switched back on as well (↘). Both detection fields (I + II) are active.

Detection field pair 2 (II) is switched off. The vehicle continues to travel with detection field pair 1 (I) active (↘).



Bild 5.3: Example: Detection field pair switch for a DTS application

## 5.2.2 Output circuit

The signal outputs are used to control indicator lamps or relays which indicate the device status. This is switched by a transistor output with open collector set to "active high" (operating voltage).

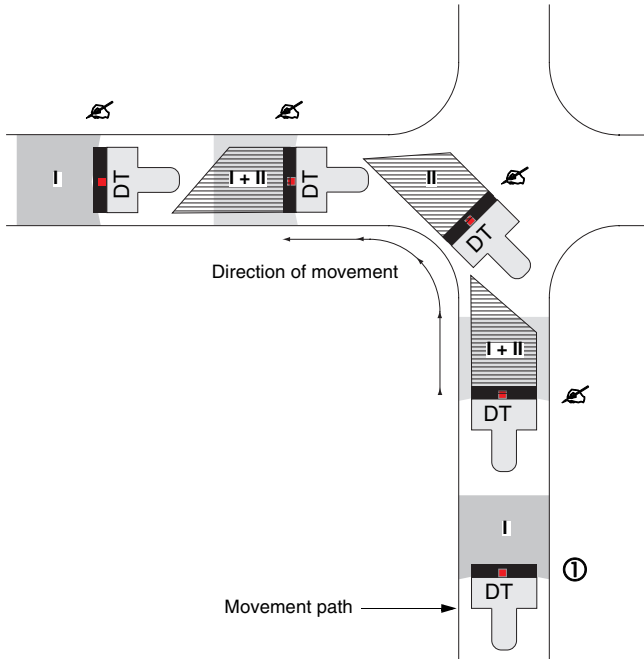

Bild 5.4: Outputs of interface X1

### "Fn1" (X1-11) and "Fn2" (X1-12)

These two semiconductor outputs report violation of the **near** detection field. X1-11 and X1-12 = "active high" signals that **no** object is located in the **near** detection field. The "low" state signals the detection of an object in the **near** detection field (see chapter 3.4 "Detection fields / detection field pairs").

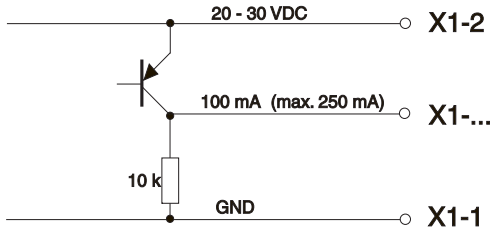

#### **Attention!**

Outputs "Fn1" and "Fn2" are tested alternately. For this purpose, the output signals are removed alternately every 20ms for a duration of 100 $\mu$ s. For this reason, the load must demonstrate lowpass characteristics, limit frequency  $f_g \leq 1$  kHz.

**The outputs must not be short-circuited. It is not permissible to connect together the outputs of two sensors.**

### "ALARM1" (X1-5)

This output is configured via the **RODsoft** configuration software.

X1-5 = "active high" signals that the device is ready for operation. The "low" output state signals one of the following states:

1. Possibility: Object detection in the **far** detection field.
2. Possibility: Device warning, e.g. light window contamination, etc.
3. Possibility: Object detection in the **far** detection field or device warning, e.g. light window contamination, etc.
4. Possibility: No signalling.
5. Possibility: Device error, e.g. faulty reference measurement.



#### **Notice!**

A device error output at alarm output "ALARM2" is also always output at alarm output "ALARM1", independent of how alarm output "ALARM1" was configured.

**Notice!**

In 4-field mode, output "ALARM1" (X1-5) signals object detection in detection\_field\_far 1. To ensure the uniqueness of the signal, you should configure alarm output "ALARM1" so that only "object detection in the far detection field" is signalled.

**"ALARM2" (X1-15)**

The "low" output state always signals a device warning or device error, independent of how output "ALARM1" (X1-5) is configured.

**Notice!**

A device error output at alarm output "ALARM2" is also always output at alarm output "ALARM1", independent of how alarm output "ALARM1" was configured.

In 4-field mode, output "ALARM2" (X1-15) signals object detection in detection\_field\_far 2.

### 5.2.3 RESTART / resetting the data transmission rate to 57600 baud

The RESTART input X1-2 has, depending on operating status, several functions:

- Release of the restart-disable following object detection in the detection field.
- Release of the start disable following a system start.

The functions are activated by applying +24VDC to input X1-2 of an **operationally ready ROD4-3...** Outputs Fn1 and Fn2 are switched off in the meantime; the display on the sensor (LED No. 3) illuminates red. A voltage of +24VDC must be applied to the RESTART input for between 0.12s and 3s.

Restart input X1-2 must be connected to an external, permanently mounted button. X1-2 must not be connected to the rest of the control as, under certain conditions, the application of a restart pulse could result in an unintended release.

**Hardware reset/resetting the data transmission rate to 57600 baud**

For this purpose, the **ROD4-3... must first be de-energised**. By applying **+24VDC for a duration of 2 ... 4s** at input X1-2 **during the power-on procedure**, the data transmission rate of the RS 232/RS 422 is reset to 57600 baud.

**Attention!**

*Do not interrupt the supply voltage during this reset procedure under any circumstances!*

*Prematurely interrupting the reset procedure for resetting the data transmission rate can put the ROD4-3... in an irreversible error state which can only be corrected by the manufacturer!*

### 5.3 Functions of connection X2

At connection X2 (9-pin Sub-D socket), either an RS 232 or 422 interface is available. It is used to

- configure the ROD4-3...,
- transfer measurement data during scanner operation.
- analyse the coordinates during the configuration (e.g. for DTS applications).
- diagnose errors and perform troubleshooting.

By default, the connector housing for the X2 9-pin Sub-D connection is delivered with a PG dummy cable gland. If the connection is not used, this connector housing ensures protection class IP 65.

We recommend using the prefabricated cable KB-ROD4PC-... (accessory) for configuring the ROD4-3... For information on fabricating cables yourself, please proceed according to chapter 5.4.2. After configuring, remount the connector housing with the PG dummy cable gland.

## 5.4 Connection

### 5.4.1 Electrical supply

The ROD4-3... requires a DC voltage of +24VDC for its electrical supply. The power consumption is

- for the ROD4-30 (without heating) max. 8W
- for the ROD4-36 and ROD4-38(with heating) max. 50W

plus the load at the outputs (max. 20W).

The power supply must be fed in via an **external fuse** (e.g. in a switch cabinet) **2.5A semi time-lag** (ROD4-30) or **4A semi time-lag** (ROD4-36, ROD4-38). Furthermore, upstream of the safeguarding, a constant current of 2.5A or 4A, respectively, is to be provided to ensure that the fuse can be tripped in the event of failure.

### 5.4.2 Fabricating the cable on the sensor side

The delivery contents include three connector housings with screwed cable gland. Two are required for holding the 9-pin SUB-D-connector and the 15-pin SUB-D-socket (PC and control cable). One housing serves to protect interface X2 if no data communication is desired with the PC.

The cable screw fittings can be used with cable diameters from 6.5mm to 10.5mm.



Bild 5.5: Plug wiring



**Attention!**

Please note that the connector housing of the control cable must be securely screwed to interface X1, and the connector housing of cable X2, or the X2 dummy cap (without cable), must be securely screwed to the ROD4-3... Corresponding threaded pins can be found on the top side of the sensor housing.

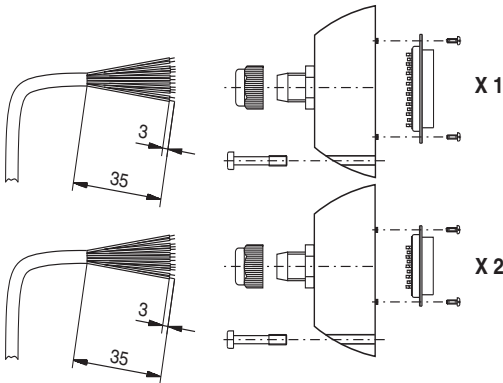
If one of the two connector housings is missing, the ROD4-3... no longer meets protection class IP 65. The connector assignments can be found in chapter 5.1.

**5.4.3 Structure of the connector**

Each connector housing consists of the following individual parts:

- Housing with sealing ring and locating pins.
- Cable screw fittings (M16) with dummy plugs.
- Sub-D 9-pin plug or Sub-D 15-pin socket, each with solder connection



**Notice!**

Information on using the config. connector at connection X1 can be found in chapter 6.3.

#### 5.4.4 Points to be observed when fabricating and laying the cable

- The **core cross section of the individual cable strands** for connection X1 must be at least **0.5 mm<sup>2</sup>**.
- Select a **cable outer diameter** between 6.5mm and 10mm.
- Maximum length of the cable for connection X1: **50m**.
- Maximum length of the cable for connection X2: **10m** (for RS 232).
- Maximum length of the cable for connection X2: **50m** (for RS 422, twisted pair).
- Use **shielded cable**.
- **On the switching cabinet side of the system, the cable shielding must only be connected to PE.**
- The cables must not be laid unsecured.

Sensor control cables must not be laid bunched together parallel to the power supply lines for machines. Inductive interference factors related to high-current-carrying motors are reduced in this way. Furthermore, the cables are to be routed in such a way that no damage (e.g. due to crushing) can occur.

As an option, sensor-side prefabricated cables are available in various lengths and for both interfaces.

## 5.5 Integration in the control system

The two following examples illustrate possibilities for connection to a control system.

After connecting the operating voltage PIN X1-3 (+U<sub>B</sub>) to PIN X1-1 (GND) and activating at least one of the detection field pairs (X1-4, X1-6, X1-7 or X1-8, see chapter 5.2.1), the device is ready for operation.

### 5.5.1 Connection example 1: without detection field pair switch

***Integrating the ROD4-3... with discrete external wiring with relay or contactor without detection field pair switch:***



Bild 5.6: Connection example without detection field pair switch

With this connection example, the restart-disable is realised by means of the command device "WA" connected at the RESTART input (X1-2). The device must, in this case, be configured with the software in such a way that the operating mode "with restart-disable" is active.

In this example, no detection field changeover is provided; only detection field pair 1 is active. For this purpose, directly connect FPS1 (X1-4) to the operating voltage VCC. The relays K1 and K2 used here have overlapping contacts (make before break) and are operated directly at the two semiconductor outputs Fn1 (X1-11) and Fn2 (X1-12).

The two semiconductor outputs possess an internal electronic current limit and are protected in the event of errors by fuse SI 2.

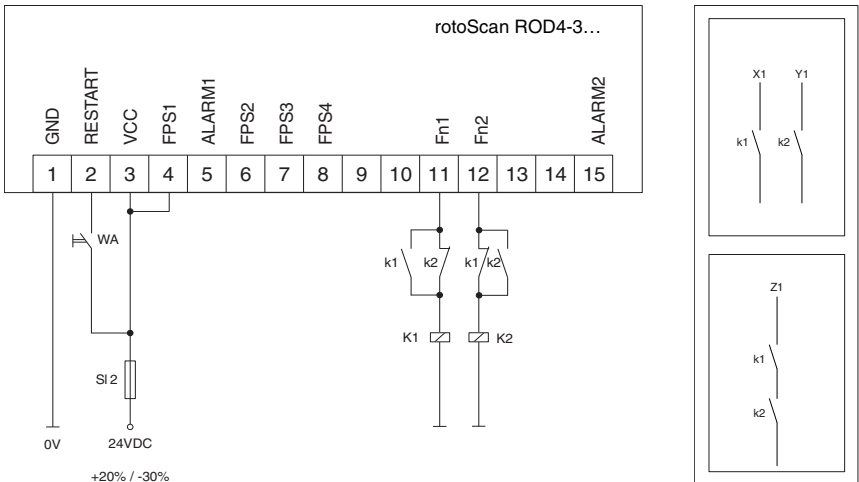
5.5.2 Connection example 2: with detection field pair switch

**Integrating the ROD4-3... with discrete external wiring with relay or contactor with detection field pair switch:**



Bild 5.7: Connection example with detection field pair switch

In this example, a detection field changeover between up to 8 detection field contours is possible via inputs X1-4 (FPS1), X1-6 (FPS2), X1-7 (FPS3) and X1-8 (FPS4) (one near and one far contour for each). The restart-disable and contactor monitoring are realised via the RESTART input.

The ROD4-3... is operated in this case in the operating mode "with restart-disable". The currently active, violated detection field is released by the command device "WA". The relays K1 and K2 used here have overlapping contacts (make before break) and are operated directly at the two secure semiconductor outputs Fn1 (X1-11) and Fn2 (X1-12).

## 6 Commissioning

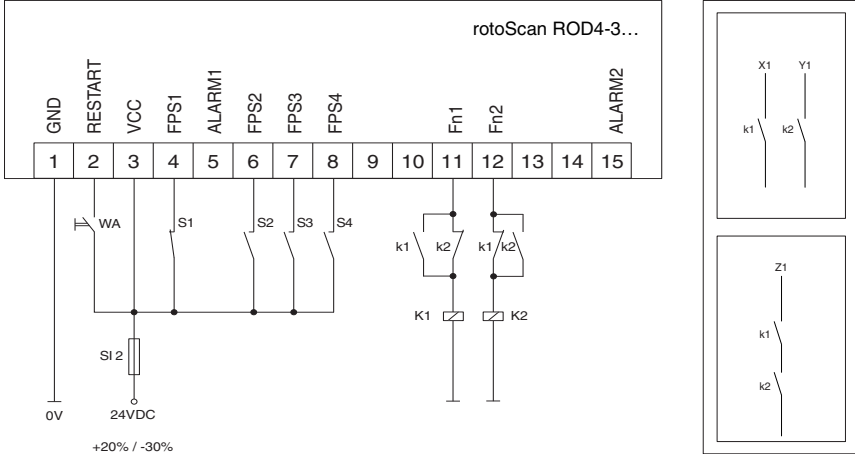
By means of appropriate configuration with the aid of the **RODsoft** configuration software, the ROD4-3... can be adapted to the given application conditions.

**Notice!**

*The **ROD4-3... models** can only be configured with **version 1.16 of the RODsoft configuration software** and higher.*

### 6.1 Hardware and software requirements

First steps with the device require the basis ROD4-3... unit, an interface cable and a PC. For the voltage supply, a power supply unit possessing the characteristics described in chapter "Technical data" on page 41 is required.

The PC used should meet the following requirements:

- Intel® processor at Pentium® level or faster (or compatible models, e.g. AMD®)
- At least 16 MB RAM
- CD-ROM drive
- Hard disk with at least 20 MB available memory.
- Free RS 232 interface (serial) or alternatively RS 422
- Microsoft® Windows 95/98/NT/2000/XP

The supplied installation CD-ROM is required for installing the **RODsoft** configuration software. The setup program is located on the CD-ROM. This program launches a self-explanatory installation routine. After the installation, the program is ready to be started.

### 6.2 Device configuration

For the device configuration, you require the configuration software "ROD-Soft", which is included in the delivery contents.

**Notice!**

*The description of the program can be found in the user manual, which is also included in the delivery contents.*

**Attention!**

*We assume here, that you perform the user-specific configuration of the ROD4-3... using this user manual.*

**Commissioning procedure:**

- Install the configuration software on the PC (setup.exe)
- Connect the ROD4-3... to the PC using a standard 9-pin sub-D cable
- Enter password "**ROD4LE**" in level "authorised customer"

**Short description:**

The current measurement values and detection fields can be displayed under "Display measurement diagram". Under "Configuration" the response times, the detection field switches and other parameters are defined. To configure the detection fields, select the "Define detection fields" field. Error codes and other information are contained in the "system data". A detailed description can be found in the user manual for the **RODsoft** configuration software.



Bild 6.1: User interface of the configuration software



**Attention!**

*Before commissioning the device, you must adjust the device parameters and the detection fields for your application. To do this, configure the ROD4-3... using the software user manual so that the detection fields are optimised for the monitoring task.*

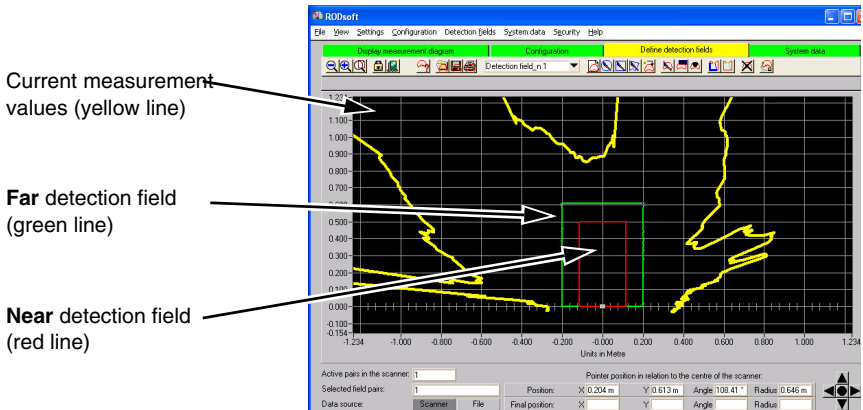
### 6.3 Device configuration with ext. configuration memory / device exchange

The optional connection cable with configuration memory is used for supplemental, permanent storage (backup) of the ROD4-3... device configuration in a memory module (EEPROM) which is integrated in the connector housing.

The ROD4-3... can be connected via the standard X1 connection cable or the connection cable with integrated configuration memory (see chapter 8.2 "Accessories"). The cable with configuration memory has the same assignments as the standard connection cable.

If the cable with configuration memory is used, note the position of the slide switch which is integrated in the connector.



Bild 6.2: Switch in the config. connector

The switch position (see figure 6.2) defines how the configuration memory functions:

- **Position "1" - left:** the ROD4-3... loads the configuration stored in the configuration memory of the cable when the device is switched on (standard setting).
- **Position "X" - right:** the configuration memory of the cable loads the configuration stored in the ROD4-3... when the device is switched on.

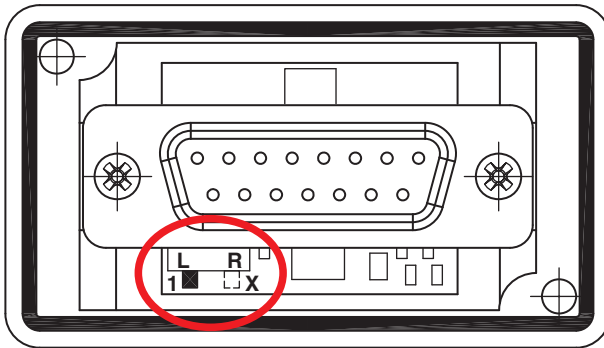

#### **Notice!**

*The default position of the slide switch is position "1". Position "X" is only necessary in exceptional cases; this is used to copy the sensor configuration to the cable.*

When the device is switched on, a check is performed to determine whether the configuration in the sensor matches that in the configuration memory. If this is the case, the sensor starts up as usual.

If the configurations do not match, then, depending on the position of the switch in the connector, the configuration is either transferred from the configuration memory to the ROD4-3... or vice versa.

Successful transfer is signalled by brief flashing of the two yellow LEDs 2 and 5 on the ROD4-3.... The configurations stored in the configuration memory and in the ROD4-3... now match. Afterward, the sensor starts up again as usual.

**Notice!**

The configuration memory of a ROD4-3... is incompatible with that of a ROD4.../ROD4-2... and, after used once, cannot be used in the respective device of the other type.

**Using the external configuration memory / exchanging devices**

If you configure the ROD4-3... with the RODsoft software and save the configuration in the ROD4-3..., the old configuration in the configuration memory is set to "invalid" and the new configuration is automatically loaded in the configuration memory of the connection cable the next time the sensor is started.

In the event of a device failure, disconnect the defective ROD4-3... from power, install the replacement device and switch the operating voltage back on. The configuration saved in the configuration memory is now transferred to the new device as described above.

**Notice!**

You can also use the connection cable with configuration memory to load the same configuration in several ROD4-3... devices without having to connect a PC/notebook.

## 6.4 Screwing down and aligning the device

The ROD4-3... is to be mounted and aligned as described in chapter 4.

## 6.5 Switching on the device

Once the device is installed, the required device parameters set and the detection fields defined, the ROD4-3... can be put into operation.

After you have switched on the voltage supply for the ROD4-3..., the red LED illuminates at first. After the red LED switches off (for free near detection field only), the ROD4-3... is ready.



Bild 6.3: LEDs

## 7 Testing and maintenance

### 7.1 Testing

The response of the detection field should be checked annually to ensure availability.

### 7.2 Cleaning

The front cover and the aperture plates of the window-monitoring photoelectric sensors should be cleaned at regular intervals (application dependent) with a soft cloth and commercially available, non-aggressive glass cleaner.



**Attention!**

*Do not use solvents or cleaning agents containing acetone. Use of improper cleaning agents can damage the optical window.*

If window monitoring continues to report a soiled cover even after cleaning the front cover and the aperture plates of the window-monitoring photoelectric sensors, the front cover must be replaced. In this case, please contact the Leuze electronic service department.



**Attention!**

*When replacing the front cover, the ROD4-3... must always be disconnected from the voltage supply. The replacement must only be performed by trained personnel in a clean environment.*

## 8 Delivery contents and accessories

### 8.1 Scope of delivery

The basic unit consists of:

- rotoScan ROD4-3...
- 2 hoods with integrated connectors with dummy plugs, including plugs for solder connection
- **RODsoft** configuration software
- rotoScan ROD4-3... technical description
- user manual for **RODsoft** configuration software

### 8.2 Accessories

The following **accessories** are available:

Part No.	Type designation	Remark
501 08138	KB-ROD4-CP-5000	Connection cable for ROD4-3x, Sub-D socket on one end, 15-pin, <b>with configuration memory</b> , cable length 5m
501 08139	KB-ROD4-CP-10000	Connection cable for ROD4-3x, Sub-D socket on one end, 15-pin, <b>with configuration memory</b> , cable length 10m
500 38069	KB-ROD4PC-3000	Configuration cable for ROD4-3, Sub-D socket/Sub-D connector, 9-pin, cable length 3m
500 38070	KB-ROD4PC-10000	Configuration cable for ROD4-3, Sub-D socket/Sub-D connector, 9-pin, cable length 10m
500 38066	BT ROD4	Mounting system for ROD4-3...
–	RODsoft	RODsoft configuration software for ROD4-3..., free download from <a href="http://www.leuze.de">www.leuze.de</a>

**8.2.1 Pin assignment for connection cables KB-ROD4-5000 and KB-ROD4-10000**

12-wire connection cable (15-pin Sub-D socket, one end)			
	PIN	Signal	Core colour
	1	GND	black
	2	Restart	blue
	3	UB	red
	4	FPS1	orange
	5	ALARM1	yellow
	6	FPS2	green
	7	FPS3	violet
	8	FPS4	grey
	9	NC	–
	10	NC	–
	11	Fn1	white
	12	Fn2	white-black
	13	NC	–
	14	NC	white-brown
	15	ALARM2	brown

### 8.2.2 BT ROD4 mounting system

The ROD4-3... can be fastened using the holes on the rear of the device. No mounting kit is necessary in this case.

It is, however, recommended that the ROD4-3... be mounted with the aid of the BT ROD4 mounting system. The advantage of this mounting variant lies in the exchangeability of the device. The device can, in this way, be removed from the mounting system and returned at a later time without readjusting the device.

With the aid of the BT-ROD4 mounting system, pitches of maximum 8° downward or upward are possible. In addition, the mounting kit allows lateral inclinations of up to ±4°.

Lateral view

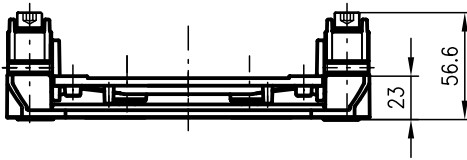

Sensor mounting surface

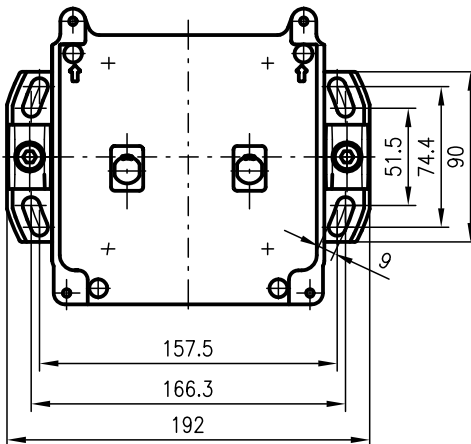

Part overview

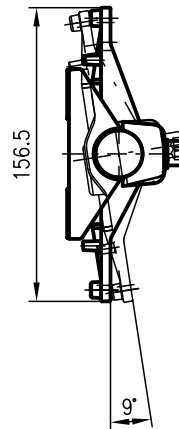

All dimensions in mm

Bild 8.1: Dimensioned drawing BT ROD4...

## 9 Technical data

### 9.1 Detection field data

Near detection field	
Radius of near detection field	0 ... 30m <sup>1)</sup>
Reflectivity	ROD4-30/ROD4-36: from min. 1.8% (matte black) ROD4-38: from min. 6%
Object size	see figure 9.1
Response time	at least 40ms (corresponds to 1 scan)
Number of detection field pairs	8 (selectable via switching inputs)
Output	two PNP transistor outputs, 24V/250mA
Start-up	the start-up testing and start disable are configured separately.

Far detection field	
Radius of far detection field	0 ... 50m <sup>1)</sup>
Reflectivity	ROD4-30/ROD4-36: from min. 1.8% (matte black) ROD4-38: from min. 6%
Object size	see figure 9.1
Response time	at least 40ms (corresponds to 1 scan)
Number of detection field pairs	8 (selectable via switching inputs)
Output	max. 2 PNP transistor outputs, max. 100mA (configurable)

- 1) Particularly in the far range, the ROD4-38 only detects large objects and objects with high diffuse reflection

Object measurement	
Measurement range	ROD4-30/ROD4-36: 0 ... 65m ROD4-38: 0 ... 25m
Luminosity coefficient	see figure 9.1
Object size	see figure 9.1
Output	serial interface RS 232, RS 422
Distance resolution	5mm
Angular resolution	0.36°
Repeatability	± 15mm

Tabelle 9.1: Technical data - detection fields

## 9.2 Electrical data

Power supply	
Voltage supply <sup>1)</sup>	+24VDC +20% / -30%, safety class III
Overcurrent protection	via fuse 2.5A (4A with heating) semi time-lag in the switch cabinet
Current consumption	approx. 400mA (approx. 2.5A with heating)
Power consumption	10 ... 50W at 24VDC
Overvoltage protection	overvoltage protection with protected limit stop
Voltage dips	acc. to EN 61496-1 (VDE 0113, part 201)

- 1) Protective Extra Low Voltage (PELV) - protective extra-low voltage with reliable disconnection.  
For UL applications: only for use in class 2 circuits according to NEC.

Inputs	
Restart/Reset	Release of the restart-disable following object detection in the detection field or release of the start disable following a system start or reset of the data transmission rate to 57600 baud. See chapter 5.2.3.
Detection field pair switch	selection between max. 8 detection field pairs via four control lines with internal monitoring, 24VDC opto-decoupled

Outputs	
For <b>near</b> detection field (Fn1, Fn2)	2x semiconductor output, PNP max. 250mA short-circuit monitored, overcurrent protected, load must demonstrate lowpass characteristics, limit frequency $f_g \leq 1$ kHz
For <b>far</b> detection field / soiling (ALARM1)	PNP transistor output, max. 100mA, configurable
For <b>far</b> detection field / warning and error output (ALARM2)	PNP transistor output, max. 100mA, configurable

Tabelle 9.2: Technical data - electrical data

## 9.3 Software

Configuration	
Configuration software	"RODsoft" configuration software under Windows 9x/NT/2000/XP/7

Interfaces	
RS 232, RS 422	device configuration and measurement data transmission

Tabelle 9.3: Technical data - software

9.4 Optical data

Optical properties	
Angular range	max. 190°
Angular resolution	0.36°
Scanning rate	25scans/s or 40ms/scan
Laser class	1 acc. to EN 60825-1, infrared laser diode, wavelength: 905nm, P <sub>max</sub> : 15W, pulse duration: 3ns, average output power: 12µW
Laser beam	approx. 15mm diameter, distance dependent, see figure 9.2

Tabelle 9.4: Technical data - optical data



Bild 9.1: Object size/diffuse reflection as a function of distance for the ROD4-30/ROD4-36



Bild 9.2: Typical beam dimensions for the ROD4-3...

9.5 Environmental data

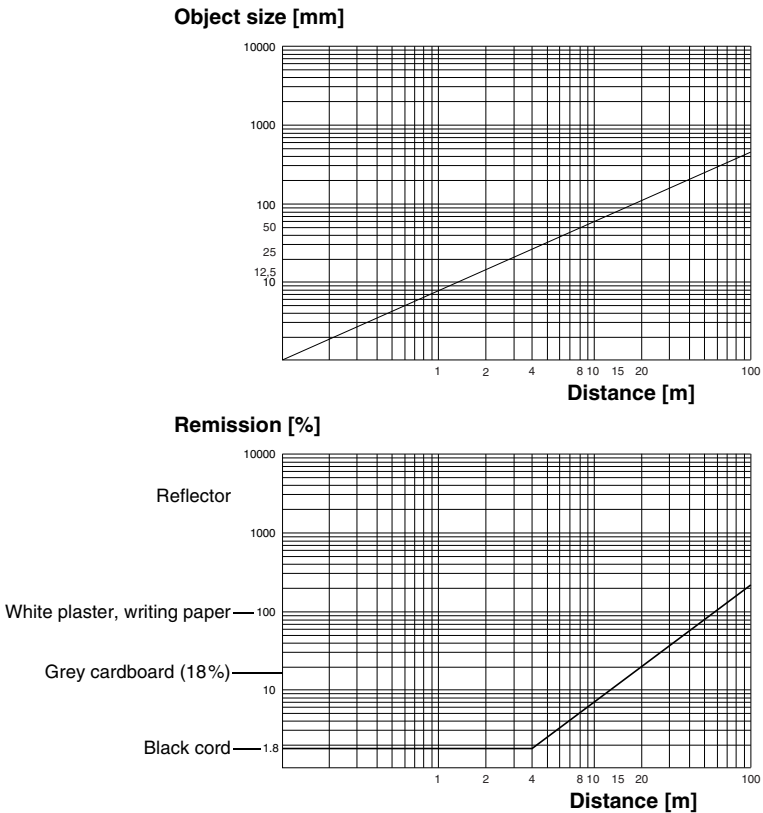
Environmental and material data	
Protection class	IP 65 acc. to IEC 60529
Contact protection	all-insulated, safety class III
Operating temperature	0°C ... +50°C, with heating -20°C ... +50°C
Storage temperature	-20°C ... +60°C
Dimensions	140x155x135 (WxHxD) in mm
Distance from scanning plane to bottom edge of housing	48.75mm
Connection	2 connectors (can be plugged from above, solder connection)
Cable length	max. 50m with conductor cross-section 0.5mm <sup>2</sup> (valid for X1 and X2 as RS 422)
Transmitter	infrared laser diode ( $\lambda = 905\text{nm}$ )
Housing	diecast aluminium, plastic
Weight	approx. 2kg
Vibrating stress	acc. to IEC 60068 part 2 - 6, 10 ... 55Hz max. 5G
Continuous shock	acc. to IEC 60068 part 2 - 29, 10G, 16ms
Interference rejection	as per DIN EN 61496-3 (in accordance with the requirements for type 4) as well as per DIN 40839-1/3 test impulse 1, 2, 3a, 3b and 5 (no application for vehicles with combustion motors)
Rotating mirror drive	brushless DC motor
Rotating mirror bearings	maintenance-free ball bearing

Tabelle 9.5: Technical data - environmental data

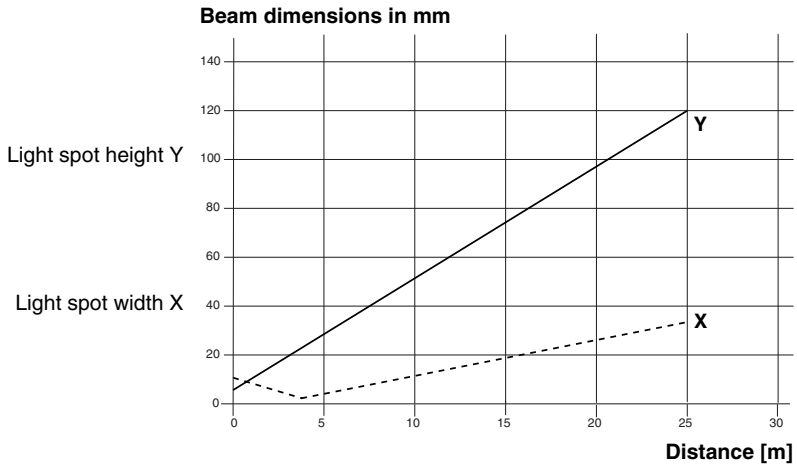
9.6 Dimensioned drawing ROD4-3...

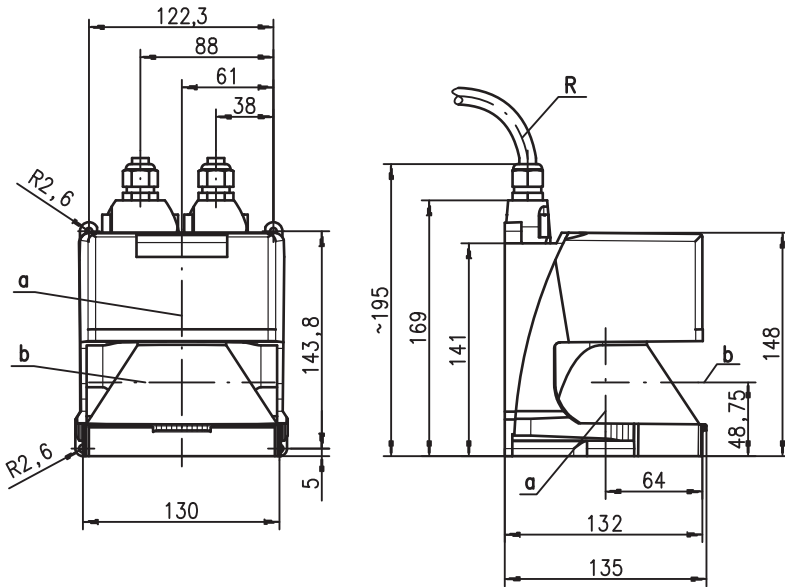

- a** Zero point for measuring
- b** Scanning plane
- R** Smallest bending radius = 50mm

All dimensions in mm



Bild 9.3: Dimensioned drawing ROD4-3...

## 10    Status messages, errors and error rectification

### 10.1    LED indicators

The status of the ROD4-3... can be read using the five LEDs located on the front side. A transparent cover protects the LEDs from contamination and guarantees protection class IP 65. When in a voltage-free state, the LEDs are hidden from view by this cover.

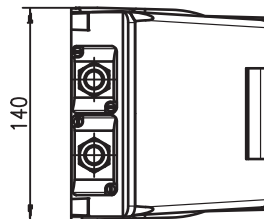

Bild 10.1: ROD4-3... LED indicators

**Overview of LED indicators**

LED	Colour	Function / Meaning
1	green	Sensor functions active, <b>near</b> detection field is free
2	yellow	<ul style="list-style-type: none"> <li>• Continuous light (<b>CL</b>):<b>far</b> detection field is occupied</li> <li>• Flashing fast (<b>FF</b>) at approx. 4Hz:Configuration from config. for a duration of 1s:connector successfully loaded (together with LED 5).</li> </ul>
3	red	<b>Near</b> detection field is occupied, Fn outputs are switched off
4	green	<b>Near</b> detection field is free, Fn outputs are active
5	yellow	<ul style="list-style-type: none"> <li>• Slowly flashing (<b>SF</b>) at approx. 1 Hz:warning message</li> <li>• Flashing fast (<b>FF</b>) at approx. 4Hz:error message</li> <li>• Flashing fast (<b>FF</b>) at approx. 4Hz:Configuration from config. for a duration of 1s:connector successfully loaded (together with LED 2).</li> <li>• Continuous light (<b>CL</b>):restart-disable locked</li> </ul>

## 10.2 Status displays

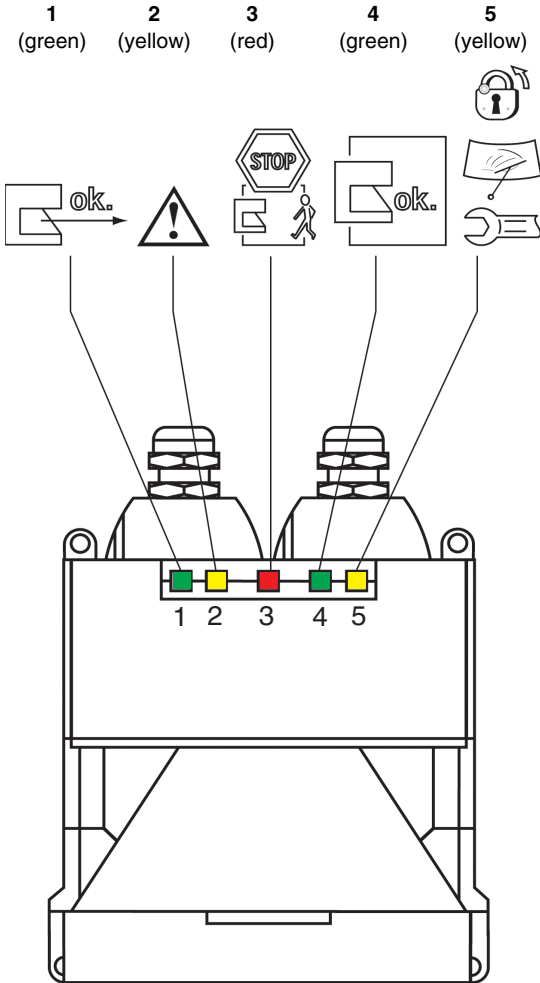

**Notice!**

The rotoScan ROD4-3... outputs two different types of messages at output "ALARM1":  
 Warning message - Information for the user indicating that a non-critical danger area (e.g. window contamination) has been detected in the device.  
 Error message - System has detected a critical device error and switches off all outputs.

LED indicators	Status
	<ul style="list-style-type: none"> <li>Near detection field is free,</li> <li>Fn outputs (X1-11, X1-12) are enabled.</li> </ul>
	<ul style="list-style-type: none"> <li>Near detection field is free,</li> <li>Fn outputs (X1-11, X1-12) are enabled,</li> <li>Far detection field is occupied, (output X1-5 "ALARM1" is enabled)</li> </ul>
 SF	<ul style="list-style-type: none"> <li>Near detection field is free,</li> <li>Fn outputs (X1-11, X1-12) are enabled,</li> <li>Warning message due to e.g. soiled front cover</li> </ul>
 CL	<ul style="list-style-type: none"> <li>Near detection field is occupied,</li> <li>Fn outputs (X1-11, X1-12) are disabled,</li> <li>Restart-disable is active</li> </ul>
 CL	<ul style="list-style-type: none"> <li>Near detection field is free,</li> <li>Fn outputs (X1-11, X1-12) are disabled,</li> <li>Restart-disable is switched on</li> </ul>
 FF	<ul style="list-style-type: none"> <li>Near detection field is occupied,</li> <li>Fn outputs (X1-11, X1-12) are disabled,</li> <li>Output "ALARM1" (X1-5) is enabled</li> </ul>
 FF      FF	<ul style="list-style-type: none"> <li>Fn outputs (X1-11, X1-12) are disabled,</li> <li>Output "ALARM1" (X1-5) is enabled</li> <li>for a duration of 1 s, configuration successfully transferred from the config. connector,</li> </ul>

Tabelle 10.1: Status displays on the rotoScan ROD4-3

### 10.3 Diagnostic codes and causes

All errors which occur in the ROD4-3... during operation are stored in a diagnostic list in the device. You can call up this list with the **RODsoft** software. On the toolbar, click  or select **System data** → **Load diagnostic data from sensor** on the menu bar.

The messages from the last 8 events are documented. This first memory slot always contains the most recent error message.

Listed in the following table are all errors together with corresponding troubleshooting notices:













Code	No	Meaning	Measure
102	2	Data transfer error on interface X2.	 Check the interface parameters and start the transfer again.
103	2	Data transfer error on interface X2.	 Check the interface parameters and start the transfer again.
104	2	Data transfer error on interface X2.	 Check the interface parameters and start the transfer again.
105	6	Function, access, command not permitted at currently selected access level.	 Change the access level and start the transfer again.
201	4	Interface X2 time specifications not complied with, last message overwritten.	 Check the interface parameters and start the transfer again.
302	2	Interface X2 time specifications not complied with, send data not acknowledged.	 Check the interface parameters and start the transfer again.
306	5	Previous message not completely issued, interface X2 time specifications not complied with.	 Check the interface parameters and start the transfer again.
801	2	Error memory cannot be read, internal defect	 If reset is not successful, contact customer service.
805	6	Error memory cannot be transferred, transmission error at interface X2	 Check the interface parameters and start the transfer again.
1002	1	Motor does not reach nominal rotational speed after start-up; internal defect.	 If reset is not successful, contact customer service.
1002	2	Motor speed not constant after start-up; internal defect.	 If reset is not successful, contact customer service.
1003	1	Motor does not reach nominal rotational speed after start-up; internal defect.	 If reset is not successful, contact customer service.
1003	2	Motor speed not constant after start-up; internal defect.	 If reset is not successful, contact customer service.

Tabelle 10.2:ROD4-3... – diagnostic codes, causes and measures

Code	No	Meaning	Measure
1003	3	Motor speed not constant after start-up; time-out.	↪ If reset is not successful, contact customer service.
1110	4	Switching outputs Fn1/Fn2 cannot be switched, short-circuit with 0 V DC or +24 V DC.	↪ Check the connection/wiring of Fn1/Fn2.
1110	5	Switching outputs Fn1/Fn2 cannot be switched, short-circuit between Fn1 and Fn2.	↪ Check the connection/wiring of Fn1/Fn2.
1110	6	Switching outputs Fn1/Fn2 cannot be switched, short-circuit with 0 V DC or +24 V DC.	↪ Check the connection/wiring of Fn1/Fn2.
1111	7	Short-circuit between switching outputs Fn1/Fn2.	↪ Check the connection/wiring of Fn1/Fn2.
1111	8	Short-circuit of one switching output (Fn1 or FN2) with 0 V DC.	↪ Check the connection/wiring of Fn1/Fn2.
1111	9	Short-circuit of one switching output (Fn1 or FN2) with +24 V DC.	↪ Check the connection/wiring of Fn1/Fn2.
1606	4	Angle error detected, poss. rotation of the sensor housing; switch-off and reset followed.	↪ If reset is not successful, contact customer service.
1607	5	Angle error detected, poss. rotation of the sensor housing; switch-off and reset followed.	↪ If reset is not successful, contact customer service.
1608	8	Motor speed not constant during operation, poss. rotation of the sensor housing.	↪ If reset is not successful, contact customer service.
1608	9	Motor speed not constant during operation, poss. rotation of the sensor housing.	↪ If reset is not successful, contact customer service.
1608	10	Motor speed not constant during operation, poss. rotation of the sensor housing.	↪ If reset is not successful, contact customer service.
1705	1	Signal of a photoelectric sensor of the window monitoring below the bottom limit, dirty front cover.	↪ Clean the front cover according to instructions (see chapter 7.2 "Cleaning" on page 37).
1705	2	Signal from a photoelectric sensor of the window monitoring above the upper limit, oil/grease on the front cover.	↪ Clean the front cover according to instructions (see chapter 7.2 "Cleaning" on page 37).

Tabelle 10.2:ROD4-3... – diagnostic codes, causes and measures

Code	No	Meaning	Measure
1906	1	Switching outputs Fn1/Fn2 cannot be switched, internal or external short-circuit.	☞ Check the connection/wiring of Fn1/Fn2. If reset is not successful, contact customer service.
1906	2	Switching outputs Fn1/Fn2 cannot be switched, internal or external short-circuit.	☞ Check the connection/wiring of Fn1/Fn2. If reset is not successful, contact customer service.
1906	5	Read back error on switching outputs Fn1/Fn2, internal or external short-circuit.	☞ Check the connection/wiring of Fn1/Fn2. If reset is not successful, contact customer service.
1906	6	Error on the laser's switch-off path, switch-off because of eye safety, internal defect.	☞ If reset is not successful, contact customer service.
1907	4	Angle error detected, poss. rotation of the sensor housing; switch-off and reset followed.	☞ If reset is not successful, contact customer service.
1907	7	Angle error detected, poss. rotation of the sensor housing; switch-off and reset followed.	☞ If reset is not successful, contact customer service.
2002	12	Configuration data displayed for inspection not acknowledged quickly enough	☞ Start the transfer again.
2007	18	Date of the currently transmitted detection field is older than the date of the detection field stored in the sensor.	☞ Update the PC's date and time setting.
2017	19	Data transfer error with ConfigPlug.	☞ Replace the ConfigPlug or the complete cable with plug.
2017	23	The connected sensor does not support the configuration file in the ConfigPlug.	☞ Change the sensor, observe the device type.
2017	24	The connected sensor does not support the configuration file in the ConfigPlug.	☞ Change the sensor, observe the device type.
2017	26	Date of the currently transmitted configuration is older than the date of the configuration stored in the sensor.	☞ Update the PC's date and time setting.
2201	5	Number of measurements in the scan too small due to rotational speed error in the motor or because internal fuse was blown.	☞ If reset is not successful, contact customer service.
2302	1	Error occurred during sensor start-up.	Sequential error.

Tabelle 10.2:ROD4-3... – diagnostic codes, causes and measures

Code	No	Meaning	Measure
2401	10	Reference measurement failed; glare from another light source (905 nm) or rotation speed error.	Sensor performed reset.
2401	13	Reference measurement failed, dust in the device, due to the plug housing or dummy cap not being screwed on.	↪ Screw the plugs of interfaces X1 and X2.
2401	41	Reference measurement failed; glare from another light source (905 nm) or rotation speed error.	Sensor performed reset.
2402	10	Reference measurement failed; glare from another light source (905 nm) or rotation speed error.	Sensor performed reset.
2402	41	Reference measurement failed; glare from another light source (905 nm) or rotation speed error.	Sensor performed reset.
2701	1	Invalid diagnostic command received, software incompatible with firmware.	↪ Use a newer version of the configuration software.
2702	3	Invalid diagnostic value requested, software incompatible with firmware.	↪ Use a newer version of the configuration software.
2800	2	2 field pair control inputs activated longer than 1 s.	↪ Check the switchover times of the control inputs FPS1 - FPS4.
2800	3	The detection field changeover which occurred does not match the preset which was programmed in the sensor.	↪ Check the activation of the detection fields in the program wizard.
2800	4	More than 2 detection fields activated during operation.	↪ Check the activation of the control inputs FPS1 - FPS4.
2800	6	Unusable or defective control voltage for the detection field activation.	↪ Check the activation of the control inputs FPS1 - FPS4.
2800	8	No detection field activated. Can occur during operation and switching off the device.	↪ If detected during running operation, check the activation of the control inputs FPS1 - FPS4.
2801	1	Error while testing the inputs for detection field changeover; internal defect.	↪ Contact the customer service.
2802	3	The detection field activation which occurred does not match the preset which was programmed in the sensor.	↪ Check the activation of the detection fields in the program wizard.
2802	4	More than 2 detection fields selected when starting the sensor.	↪ Only activate one of the control inputs FPS1 - FPS4.
2802	6	Unusable or defective control voltage for the detection field activation.	↪ Check the activation of the control inputs FPS1 - FPS4.

Tabelle 10.2:ROD4-3... – diagnostic codes, causes and measures

Code	No	Meaning	Measure
2802	8	No detection field activated during start-up of the sensor.	☞ Activate one of the control inputs FPS1 - FPS4.
2804	3	The detection field activation which occurred does not match the preset which was programmed in the sensor.	☞ Check the activation of the detection fields in the program wizard.
2804	4	No detection field clearly selected.	☞ Check the activation of the control inputs FPS1 - FPS4.
2804	6	Unusable or defective control voltage for the detection field activation.	☞ Check the switchover times of the control inputs FPS1 - FPS4.
3016	11	Confirmed single password entered wrong.	☞ Repeat the password entry.
3203	6	Sensor has optical glare caused by another device.	☞ Switch off the supply voltage and start the sensor again.
3203	7	Sensor has optical glare caused by another device.	☞ Switch off the supply voltage and start the sensor again.

Tabelle 10.2:ROD4-3... – diagnostic codes, causes and measures

## 11 Appendix

### 11.1 Terms and abbreviations used with ROD4-3... and the RODsoft software

#### Alarm output ALARM1

Semiconductor output which signals a device warning and error and/or occupancy of a detection field. The function can be selected in RODsoft via the "alarm signal type". The output is at pin 5 of interface X1 and is designated in the ROD4 handbook as ALARM.

#### Alarm output ALARM2

Semiconductor output which signals a device warning and error. The output is at pin 15 of interface X1 and is designated in the ROD4 handbook as WARN.

#### Start disable

Following device start-up, the restart button must be actuated in order to activate the outputs.

#### Start-up test

Following device start-up, the near detection fields must be clear after the start-up delay period has passed; the outputs are switched off. To activate the outputs, at least one near detection field must be occupied and then again be cleared.

#### Start-up delay

Configurable time which must pass before a permanently clear near detection field activates the corresponding switching output. The start-up delay for far detection fields is permanently set to 80ms.

#### Response time

Time which must pass before a permanent detection field occupancy switches off the corresponding switching output (separately configurable for near and far detection fields).

#### Output start-stop segment, output resolution

Used to configure the measurement value transmission at serial interface X2. The configuration is made in multiples of  $0.36^\circ$ . A detection range of  $180^\circ$  corresponds to a start segment of  $14 \cdot 0.36^\circ$  and a stop segment of  $514 \cdot 0.36^\circ$ . If the output resolution is  $> 1 \cdot 0.36^\circ$ , the minimum value within the resolution interval is transferred/displayed. Notice: Monitoring of the detection fields also occurs outside of the configured transmission range.

#### F

Field

#### Detection field

Long version of the term **field**.

**Near detection field**

Max. detection range 30m, object detection within the **near** detection field affects outputs Fn1 (pin X1-11) and Fn2 (pin X1-12). The **near** detection field is represented in the user interface of the RODsoft configuration software by the colour red.

**Fn**

Short version of the term **near detection field**.

**Far detection field**

max. detection range 50m, object detection within the **far** detection field affects output ALARM1 (pin X1-5, depending on the configuration). The **far** detection field is represented in the user interface of the RODsoft configuration software by the colour green.

**Ff**

Short version of the term **far detection field**.

**FP**

Field pair, detection field pair;  
the configuration software can be used to configure up to 7 field pairs in the ROD4-3..., each with two detection fields (**near** and **far**).

**FP1**

Field pair 1.

**FPS**

Field pair switch.

**Minimum object size**

This parameter is permanently stored and is calculated from the maximum radius of the detection field. Objects are detected if at least the minimum number of consecutive scanning beams (multiple of 0.36°) is incident on an object.

**Scanning rate**

Rotational frequency of the scanner deflection mirror = 25Hz.

**Sector size**

This parameter can be changed. If the value for the sector size is  $> 1$ , objects are detected if the minimum number of consecutive scanning beams (multiple of 0.36°) is incident on an object. If the sector size is  $> 1$ , the entry for minimum object size is immaterial.

### Serial interface baud rate

Used to configure the transmission rate (9.6 ... 687.5 kBit/s) at serial interface X2 of the sensor. The baud rate is continuously changed in the sensor.

#### Important notice:

If the baud rate is changed, a PC cannot initially be connected to the sensor via RODsoft. This must first be adjusted in RODsoft with the **Settings** → **PC configuration** – > **Interface** menu command (max. 115200Baud at RS 232). We recommend working with the factory setting of 57600 Bd.

If the baud rate at X2 is set to a value higher than 115200Baud, a connection is no longer possible with RODsoft via the RS 232. Resetting to 57600 Bd can then only be performed via an external connection at pin X1-2 (see chapter 5.2.3 "RESTART / resetting the data transmission rate to 57600 baud").

### Dust suppression

With the introduction of the new ROD4-3... models, considerably more effective dust suppression was implemented in the devices. With activated dust suppression (recommended), sensor availability is significantly increased in the event of small particles in the air, such as insects. This also maximises the time which may pass before cleaning of the front cover becomes necessary.

Dust suppression is implemented globally, i.e. it is used in all detection fields. In the RODsoft configuration software, 3 parameters determine the function of the dust suppression (factory setting: activated):

- the object size (factory setting: 70mm)
- the object speed (factory setting: 1600mm/s)
- the response time (factory setting: 80ms)

#### *Object size*

This dust suppression parameter defines the maximum size up to which interfering objects (e.g. particles in the air) should not be detected. Values that are too large prevent object detection. Values that are too small increase the sensitivity to interfering objects. The 'Automatic' setting results in less efficient dust suppression.

#### *Object speed*

The object speed specifies the maximum speed of the objects that are to be detected; if necessary, the speed of the sensor itself is to be taken into account. Values that are too small prevent object detection. Values that are too large and the value '0 mm/s' increase the sensitivity to interfering objects.

**Comment:**

Speed refers not only to the speed at which an object moves toward the sensor (speed component  $v_x$  in figure 11.1); it generally refers to the maximum speed with which objects may move in the detection field (speed components  $v_x$  and  $v_y$  in figure 11.1). As area scanning occurs in the XY plane, speed component  $v_z$  cannot be detected and evaluated. The maximum object speed can be best optimised through testing.



Bild 11.1: Components of the object speed

**Response time**

Another important parameter is the response time. The longer the selected response time, the more calculating time is available for the dust-suppression algorithm and, thus, the more powerful the dust suppression. With a response time < 80ms, only the object size is evaluated.

Dust suppression is more efficient the:

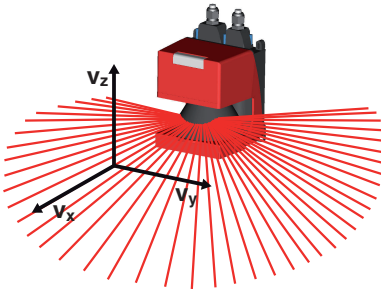
- greater the selected object size
- lower the selected object speed
- longer the response time

It is a good idea to optimise the values preset ex works (object size: 70mm, object speed: 1600mm/s, response time: 80ms) for the respective application through practical tests.

**Notice!**

*Compatibility mode for old ROD4/ROD4-2... models:*

- Object size 'automatic'
- Object speed: 0 mm/s

**Config. connector:** *If a ConfigPlug with ROD4-3x configuration (with new dust suppression) is plugged into a ROD4/4-2x, the configuration is accepted, but the old dust suppression used!*

**RODsoft:**

*If a ROD4-3x configuration with new dust suppression is loaded from a file while a ROD4 or ROD4-2x is plugged in, the new dust suppression parameters are not displayed. The sensor uses the old dust suppression following the transfer. The ROD4-3x configuration becomes a ROD4-2x compatible configuration.*

*A ROD4-3x configuration can also be loaded if a ROD4/4-2x was selected. The new dust suppression parameters are not displayed in this case. The scanner uses the old dust suppression following the transfer.*

**Restart**

Determines how switching outputs are switched following object detection in a near detection field in the event of subsequent non-occupancy.

- Manual restart: The restart button must be actuated and start disable must be active.
- Automatic restart: Following a start-up delay, the outputs are activated.

**Angular resolution**

Smallest technically possible resolution of the sensor in angular degrees.